



GLOBE VALVES

INSTALLATION,OPERATION,MAINTENANCE MANUAL

TABLE OF CONTENTS

| | |
|--|--------|
| 1.0 Transportation and Storage..... | Page 1 |
| 2.0 Prior Installation..... | Page 1 |
| 3.0 Installation | Page 2 |
| 4.0 Operation | Page 3 |
| 5.0 Usage attention..... | Page 3 |
| 6.0 Troubleshooting..... | Page 4 |

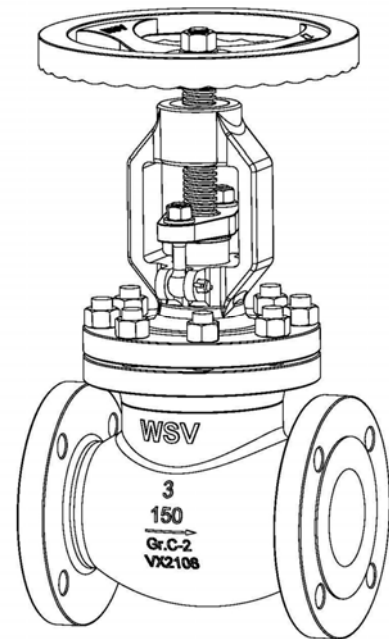

The manual provides customers with all information on Weidouli globe valves storage, installation, operation and maintenance.

a) This manual being applied substantially, it is essential to take proper measure that comes from the experience and common idea the operator

b) Such information as technical data on relevant dimensions, spare parts, part material, tools, fixtures are not covered in this manual. Details refer to each purchase order and Weidouli GA drawings.

1.0 TRANSPORTATION AND STORAGE

1.1 Transportation.

- a) The valve and the actuator can be integrated or separated to be placed in the plywood case(s) suitable for transportation. Each plywood case is marked with gross weight, net weight, case number and other related mark.
- b) While loading or unloading, check for and adhere to any markings or arrows on the box which may be present to indicate upward orientation.
- c) The user should select proper tools and lifting equipment to transport the goods to avoid

damages to it after transported to the warehouse or outdoor storage of the installation site.

1.2 Storage

- a) The valve should be kept in a dry and airy environment indoors and valve both ends should be blocked.
- b) Valves should be checked regularly in long-term storage, to remove the dirt. Pay attention to keep the sealing surface clean, and avoid sealing surface be damaged.

2.0 PRIOR TO INSTALLATION

- 2.1 Ensure Working conditions are within the specified capacity of the product being installed. Refer to the certified Engineering drawings to assist in determining these values.
- 2.2 Make sure that the construction material of the Globe Valve is chemically compatible with the media flowing in the pipeline.
- 2.3 Rotate the hand wheel to check whether valve rotation is flexible and positioning accuracy.
- 2.4 Make sure packing seals be compressed

tightly, do not prevent the stem rotation.

- 2.5 Inspect the Globe Valve's ends and the pipeline's ends to ensure the surfaces are clean and free of defects. The pipeline should also be checked for proper alignment.
- 2.6 The distance between pipe flanges should be checked to assure sufficient clearance for valve
- 2.7 Regular check on valve's seals surface, stem and gasket, packing etc. parts. If any parts broken, should repair or replace in time.

3.0 INSTALLATION

3.1 Check that the existing pipe sizes match the inlet and outlet sizes of the unit being installed. If pipeline strain is a concern with larger Globe Valves and accessories, additional support may be necessary.

3.2 Pay attention don't let the foreign matter enters the valve and don't strike the valve surface with the tool, to prevent valve from defect.

3.3 Valve shall be horizontally installed, keep the valve stem perpendicular to floor, refer to sketch A.

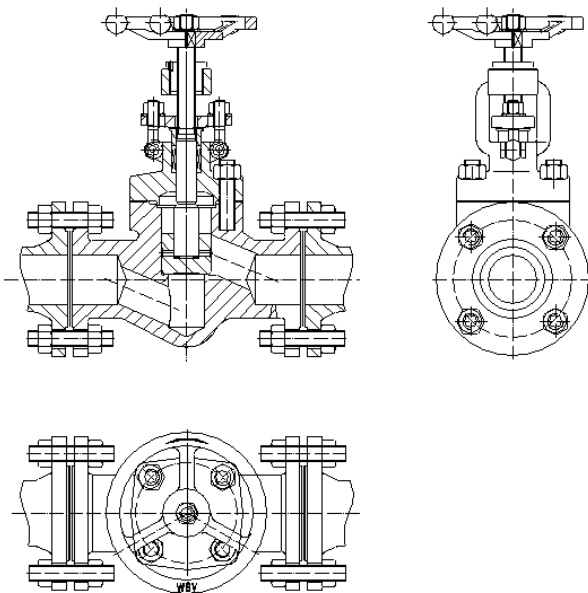

sketch A

3.4 For NPT ends valves, it is recommended that the valve is mounted in the closed position. Gently thread valve to mating pipe by hand until resistance is felt. Using a wrench tighten the valve using hex flats at the joint being tightened. Do not tighten through the valve body using hex flats on opposite end of joint being tightened.

3.5 For welding ends valve, it is recommended that the valve be in the open position. Care must be taken to apply the proper amount of solder so that it does not flow into valve seat area. Depending on the fuel selected and the orientation of the installation it may be necessary to wrap the valve body with wet rags or employ other heat absorbing techniques. The cup should be heated evenly. Once one of the joints is complete, the valve should be allowed to cool until "cool to touch" before beginning the second joint.

3.6 For flanged ends valve, install lubricated flange bolts and hand tighten. Flange bolts should then be tightened, using a star or crisscross pattern to evenly load the bolts, in accordance with established piping standards. Mall cap screws on the inlet and the outlet of the valve.

4.0 .OPERATION

4.1 The using temperature and pressure conditions of valve should not exceed the maximum limited temperature and pressure.

4.2 Inspect flange connections for leaks. If leaking occurs, check for piping misalignment, that the flange bolts are properly tightened, and that the cover is properly seated.

4.3 Working condition do not exceed the valve

performance limitations.

4.4 Adjusting flow from 0° (closed) to 90° (full flow) can be done manually or automatically depending on the type of globe valve installed.

Manual operators are available in a 10 position handle, an infinite handle, and a gear operator.

4.4 Valves should be opened and closed slowly to avoid hammering effect on the valve.

5.0 USAGE ATTENTION

5.1 The working temperature should bear in the stipulation, any deviation should in the charge of user. The surface temperature may cause the scald when valves working, the user should mark the warning on the part.

5.2 The maximum pressure should not beyond the contract indicate. Any overstep should on user's own.

5.3 It is recommended that lifting straps (instead of chains or hooks) be used around the valve yoke neck and through the flange bolt holes for pressure points.

5.4 Never lift or move the valve assembly using

the disc, valve seat (bore) or packing follower/nut as a pressure point.

5.5 Never lift or move the valve assembly by using the actuator, positioner, tubing or other accessories.

5.6 No welding or coating is allowed when valve is working.

5.7 No life calculation, test and fatigue strength when design, the user should periodically check and replace it.

5.8 Prohibit adding or replace packing when the valve under use and pipeline with pressure. This could lead to serious injury.

6.0 TROUBLESHOOTING

| Problem | Causes | Remedies |
|---|---|--|
| Leakage at packing | <ol style="list-style-type: none"> 1. The packing gland is too loose. 2. Packing coil are not enough. 3. Packing is used too long or kept improperly to be ineffective. | <ol style="list-style-type: none"> 1. Evenly tighten the screw nut to lock up the packing gland. 2. Increase the packing coils. 3. Replace packing with new one. |
| Leakage between seal faces | <ol style="list-style-type: none"> 1. Filth is attaching to the seal faces. 2. Seal faces are damaged. | <ol style="list-style-type: none"> 1. Clear up filth completely. 2. Repair the seat and the seal faces. |
| Leakage at the junction of body and gland | <ol style="list-style-type: none"> 1. The connecting bolts are not tightened evenly. 2. The seal faces of flange are damaged. 3. The washer cracks or loses effectiveness. | <ol style="list-style-type: none"> 1. Evenly tighten the bolts. 2. Repair the seal faces again. 3. Replace the washer. |
| <p>Uneasily to turn hand wheel;</p> <p>The Disc can't be open or closed</p> | <ol style="list-style-type: none"> 1. Packing is pressed too tight. 2. The packing gland and/or gland bushing is inclined. 3. There are damaged screw nuts. 4. The threads of stem screw nut are seriously worn or crack. 5. The stem bends. | <ol style="list-style-type: none"> 1. Properly loosen the nuts on the packing gland. 2. Correct the packing gland and gland bushing. 3. Dismount to repair the threads and clear filth. 4. Renew the stem screw nut. 5. Correct the stem. |