



BUTTERFLY VALVES

INSTALLATION, OPERATION, MAINTENANCE MANUAL

TABLE OF CONTENTS

1.0 Prior to Installation.....	Page 1
2.0 Installation.....	Page 1-3
3.0 Operation.....	Page 3-4
4.0 Maintenance.....	Page 4-5
5.0 Troubleshooting.....	Page 6

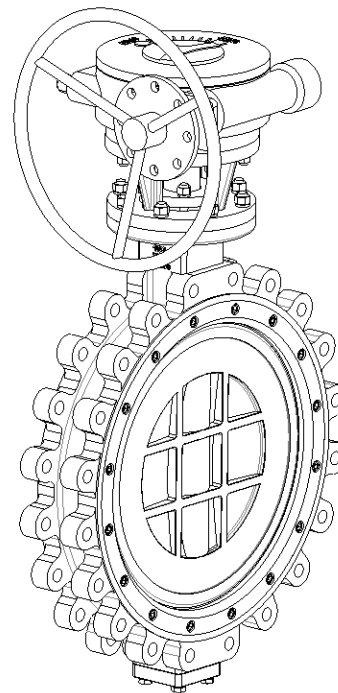

The manual provides customers and end-users with all information with regards to the storage, installation, operation and maintenance of Weidouli Butterfly Valves.

a) This manual should be used in conjunction with practical measures learned from both maintenance and operational experience. Ensure that only suitably skilled and experienced personnel can handle and maintain the valves.

b) Such information as technical data on relevant dimensions, spare parts, part material, tools, fixtures are not covered in this manual. For such details, please refer to each purchase order and Weidouli General Arrangement (GA) drawings.

c) If you have any doubt, queries, questions or require additional information or clarification, please contact the Weidouli office.

1.0 PRIOR TO INSTALLATION

Transportation and Storage

1.1 Transportation.

- a) The valve and the actuator can be integrated or separated to be placed in the plywood case(s) suitable for transportation. Each plywood case is marked with gross weight, net weight, case number and other related marks.
- b) While loading or unloading, check for and adhere to any markings or arrows on the box which may be present to indicate upward orientation.
- c) The user should select proper tools and lifting equipment to transport the goods to avoid damage after it has been transported to

the warehouse or outdoor storage area at the installation site.

1.2 Storage

- a) **IMPORTANT:** Don't expose the valves to dust, sand or similar materials during storage.
- b) For transport and storage, the valves must always be in the closed position and the connection ends must be protected to prevent damage to the seats. To prevent damage, do not suspend the valve by its lever, gearbox or actuator.
- c) Storing in the closed position will minimize the risk of damage to the seats

2.0 INSTALLATION

2.1 **IMPORTANT:** The Butterfly should be in the full close position before valve installation.

2.2 Before installation, remove the end protectors and clean the valve ends and bore. Check that the valve and its accessories have not been damaged during transportation.

2.3 Before the installation, please check the instruction carefully and ensure conditions are consistent with the requirements of the valve that is being used.

2.4 If the valve has been in storage for a long period, please ensure that the valve is properly cleaned and tested prior to installation and that

all moving parts are able to move without undue restraint. This is to ensure that the valve will perform reliably and satisfactorily during operation.

2.5 Before installing the valves, the pipes must be flushed clean of all debris, weld slag, dirt etc. to prevent damage to the seats and the Butterfly surface. Failure to do so may result in damage to the soft seat, metal seat and other parts during operation.

2.6 The gaskets at the connecting flanges must be installed properly. Use only joints and gaskets made from approved materials.

2.7 The valve body when marked with an arrow indicating the flow direction, the valves should be installed in such a way that the actual flow direction of the medium matches the arrow on the body.

2.8 If the valve is actuated, all electrical equipment such as actuators, limit switches etc. must be installed in flood-proof and dry locations and conditions. Pay attention to the recommended voltage and frequency.

2.9 When installing a valve between two flanges, ensure there is adequate space to install flange seals gaskets and ensure the counter flanges do make contact with the valve sealing surface.

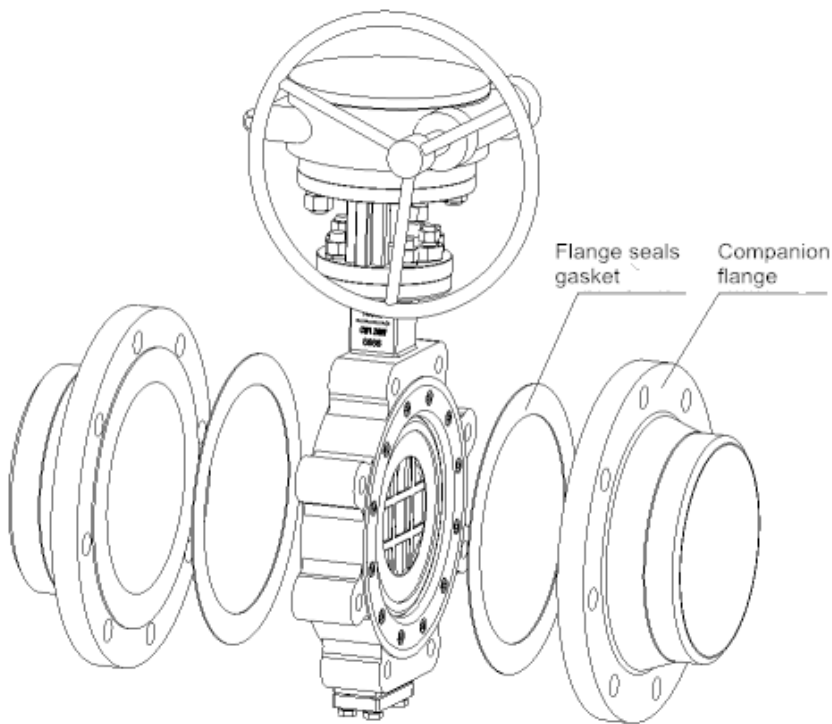

2.10 Use the correct size counter flanges, gaskets and fasteners, these parts should be suitable for the operating conditions. Flanges bolts should be tightened, using a tool to evenly load bolts.

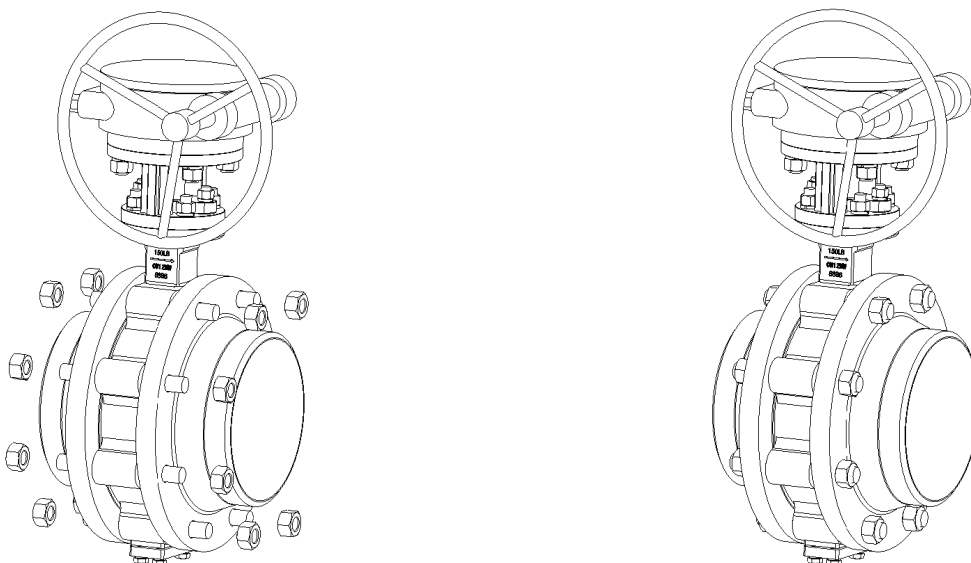

2.11 Handling Procedure

A- It is recommended that lifting straps (instead of chains or hooks) be used around the valve yoke neck and through the flange bolt holes for pressure points.

B- Never lift or move the valve assembly using the disc, valve seat (bore) or packing follower / nut as a pressure point.

C- Lifting of large valves. Never lift or move the valve assembly by using the actuator, tubing or other accessories. Select proper tools and lifting equipment to transport the goods. To hoist the valve, the actuator should not be the pick-up point.

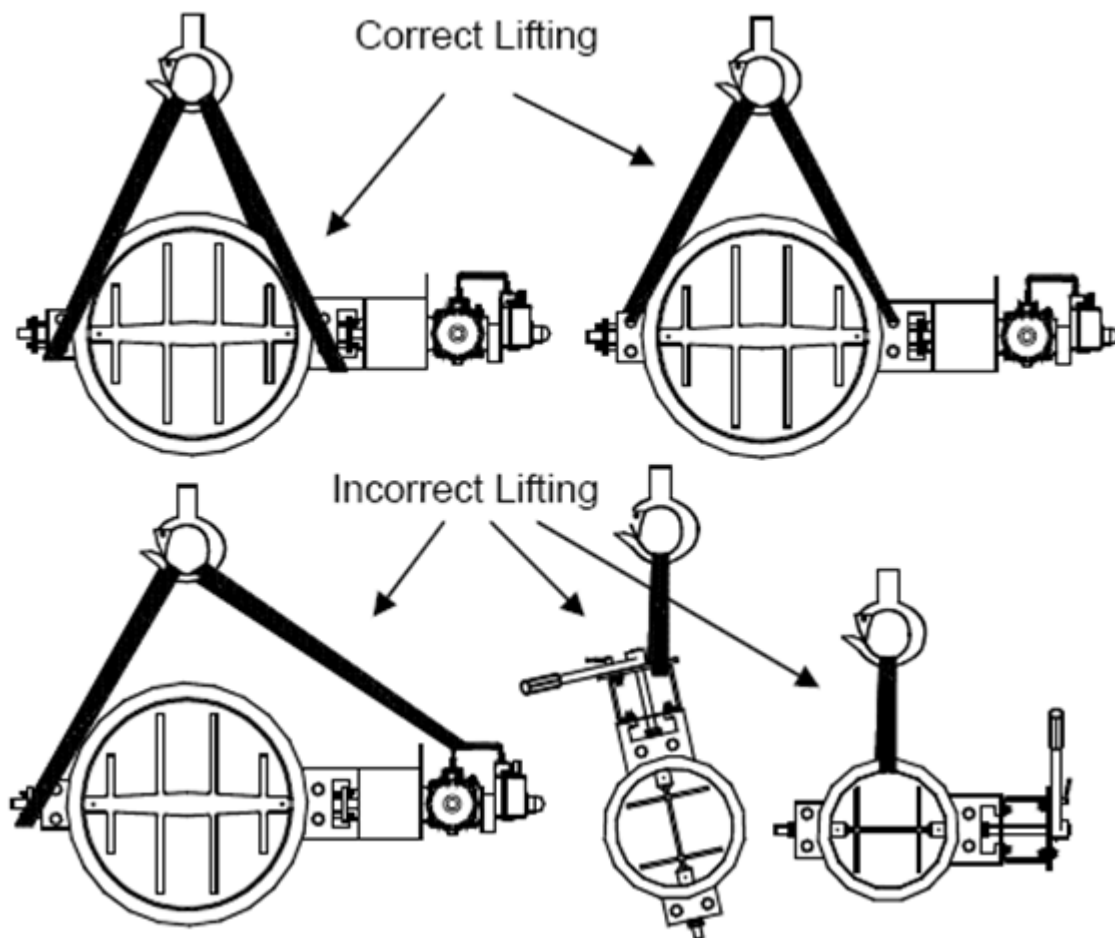

3.0 OPERATION

3.1 Prior to commissioning of the valve, the pressure, temperature and material data sheet on the valve should be compared to the actual operating conditions in the piping system to check whether the valve can withstand the loads that occur in the system.

3.2 The valves must not be operated beyond the limits. The actual or operating temperature and pressure conditions of the valve should not exceed the maximum limited temperature and pressure. Nonobservance of this warning may lead to personal injury or property damage.

3.3 When the valve is used in a pipeline, it should be fully open or fully closed, and the semi-closed or half-open state for long periods should be avoided as this may cause damage to sealing rings

3.4 Valves should be opened and closed slowly to avoid hammering effect on the valve.

3.5 The handling a valve requires skilled and

experienced personnel. Human errors due to Operator's poor or lack of skill in operating the valve may have serious consequences for the entire plant, such as fluid escape, downtime of the plant.

3.6 Before operation, the gland packing should be checked when it is subjected to the full operating pressure and temperature for the first time, if necessary, evenly re-tighten the nuts at the gland flange.

3.7 The counter flanges connection and gasket should be checked for tightness after the application of pressure in the valve. Should a leakage at the gasket face be observed, the connection should be tightened evenly and crosswise, and in a clockwise direction.

3.8 Once proper installation has been successfully completed, gradually increase system pressure until working pressure is reached.

4.0 MAINTENANCE

4.11 Before removing the valve from the pipe, the valve must be depressurized, as opening of pressurized valve may cause and injury or even death. Furthermore, care should be taken that the valve under consideration and its associated fluid has cooled down sufficiently to prevent injury and due to scalding and burning.

4.12 Adequate care should be taken to avoid not to damage the sealing surface of parts during disassembly and reassembly.

4.13 Depending on the installation position, any liquid remaining in the valve may have to be removed. Prior to transport, the valves must be flushed and carefully drained.

4.14 Depending on the working medium and situation, if necessary, wear suitable protective clothing.

4.15 If the actuator is powered by an external source of energy such as electric, pneumatic, hydraulic power which need to be removed or

dismantled from valves, the energy supply must be shut down prior to starting any maintenance work.

4.16 To ensure reliable operation and to reduce repair costs, all valves especially those which are seldom operated or where access is difficult should be checked periodically.

4.17 Don't use unauthorized replacement spares and parts.

4.18 New parts should be cleaned before assembly.

4.19 Use grease for lubrication. The grease should be compatible with all metal materials and rubber and plastic parts of the Butterfly valve as well as the working medium. When the working medium is gas, special grease may be used. Apply a thin film of grease onto the surface of the mounting groove of sealing elements, the rubber sealing elements and the sealing and friction surfaces of the stem.

4.20 During assembly, no metal scraps, fibers, grease (except those stated), dust or any other impurities can pollute, adhere to or stay on the part surfaces or enter into the inner chamber.

4.21 On-line Maintenance

The replacement of the stem packing, fire-protection ring etc. and similar parts can be conducted on the pipeline, without having to

disassemble the valve from the pipeline. The disassembly order is different in accordance with different actuator types.

4.22 Butterfly valve -replacing packing

- 1) Shut off the cut-off valves in the upper and lower reaches of the Butterfly valve. Vent the air to relieve the pressure in the pipeline sections before and after the Butterfly valve.
- 2) Make the Butterfly valve fully closed.
- 3) Release the screw to unload the packing gland.
- 4) Remove the packing with the hooked iron wire.
- 5) Check the unloaded parts. Repair or replace them in case of damage. Clean the packing.

- 6) Wipe and lubricate the sealing surface of the packing gland.
- 7) Load the new packing.
- 8) Load the packing gland in the opposite order of unloading and then tightening the screw.
- 9) Then load the first clip ring, the locking block, the handle and the second clip ring.
- 10) Operate the handle to check the on-off flexibility of the Butterfly valve.
- 11) Carry out the pressure test.

4.23 Off-line Maintenance---Replacing Seat, Gasket Ring, Fire-protection Ring and So on

It's very important to take the following measures to conduct any disassembly

operations for the valve in the working state to ensure your safety.

4.3.1 How to unload valve from pipeline

- 1) To unload a valve with an actuator, close the valve first and then separate the auxiliary jackets, pneumatic or electric connecting wires.
- 2) As for working on the valve when the

medium remains in the pipeline, ensure the appropriate protective personal clothing (PPE) is worn.

- 3) Relieve the pressure of all pipelines, empty the fluid medium in the system, and open and close the valve for as many times as is necessary to exhaust any remaining pressure.

Caution!

The valve should not be disassembled in a closed state

5.0 TROUBLESHOOTING

Faults	Probable cause	Solution
Internal and external leakage	Over pressure and temperature	Keep attention on maximum allowed operating pressure and temperature.
	Demands and requirements by aggressive medium	Use appropriate material for related service.
Seat leakage	Impurities in medium damage seat	Disassemble, clean and replace seat with a new one.
	Disc not fully closed or past fully-closed position	Check whether in correct position.
	Too high medium temperature causes damages to seat	Check suitability of seat material to the medium and its temperature
	Closing position of actuator is not properly set	Adjust limit screw of actuator
Leakage from Stem	Fixing nut or locking bolt is loose	Tighten nut or bolt
	Stem or top gasket is damaged	Replace stem or top gasket
	End face of support to mount actuator is not vertical to axial line of stem.	Calibrate verticality of support end face to stem axial line.
Middle flange seal leakage	Middle flange bolt and nut are loose	Tighten middle flange bolt and nut;
	Flange end face of valve is unparallel with that of pipeline.	Correct position between flanges until they are parallel.
Working condition over limit	Fluid temperature is too high	Check designed applicability of material;
	Air supply of pneumatic valve is under-pressure	Supplement pressure of air supply to normal value;
	Operating handle is too short	Turn seat or seat seal to discharge extra pressure.
If have	Damages are caused during transportation.	Replace damaged part and make a record;